

REMS Rollnutvorrichtung

REMS Rollnutvorrichtung Teilverzeichnis

Aktueller Stand
siehe www.rems.de

REMS Roll Grooving Attachment Spare parts list

Latest version
see www.rems.de

Dispositif à rainurer REMS Liste des pièces

Situation actuelle
voir www.rems.de

REMS Dispositivo per scanalare Elenco dei pezzi

Ultimo aggiornamento
vedi www.rems.de

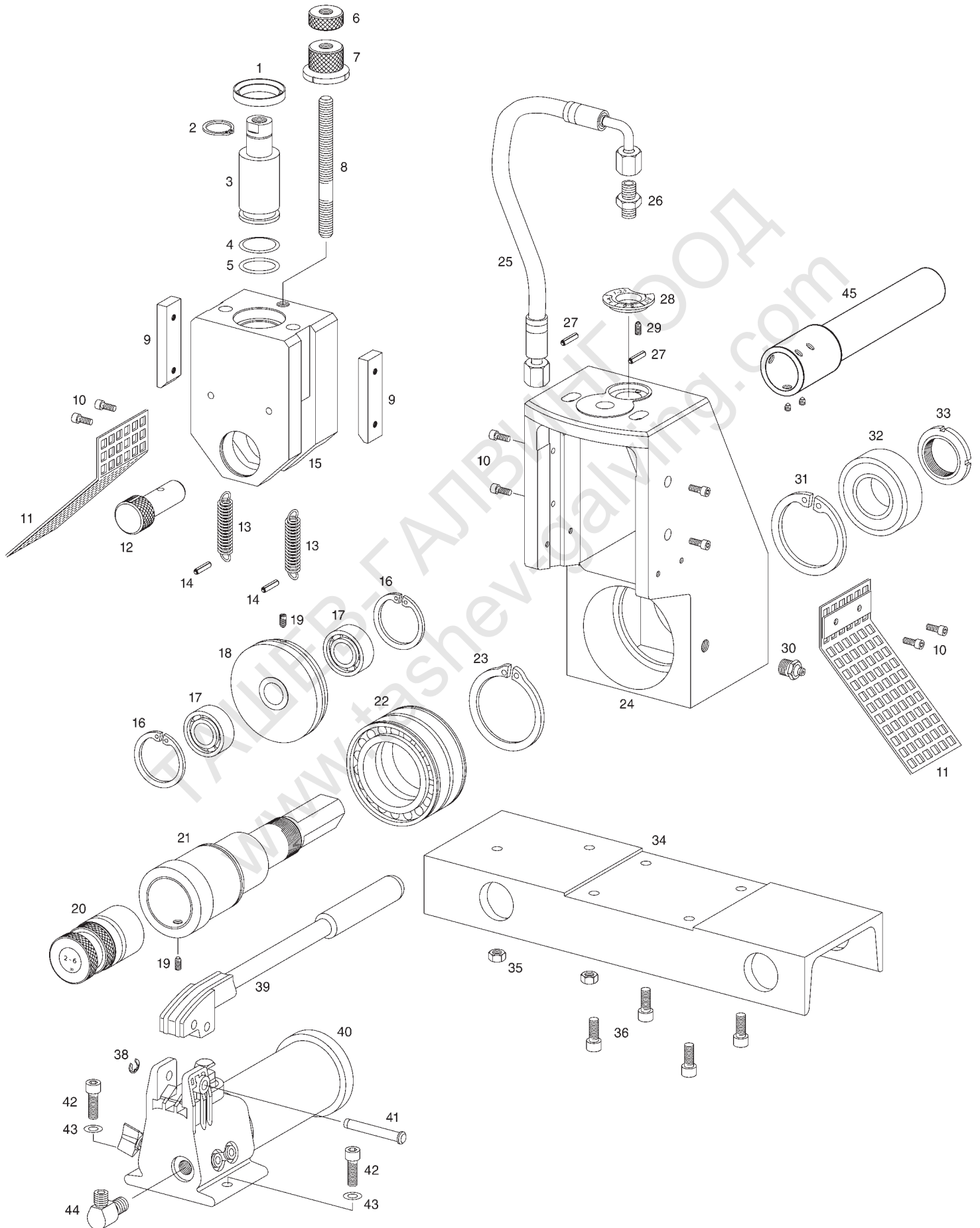

deu	eng	fra	ita		
1	Abstreifer	Shedder	Dévêtisseur	Slingettatore	060266
2	Sicherungsring	Locking ring	Circlip	Anello di sicurezza	059010
3	Kolben	Piston	Piston	Pistone	347104 R
4	Stützring	Back-up ring	Bague d'appui	Rondella d'appoggio	060245
5	O-Ring	O-ring	Joint torique	Guarnizione O-Ring	060244
6	Konterrad	Counter wheel	Contre-écrou	Controruota	347108 R
7	Einstellrad	Setting wheel	Roue de réglage	Ruota di regolazione	347107 R
8	Spindel	Spindle	Arbre	Albero	347106 R
9	Führungsleiste	Guiding plate	Plaque de guidage	Piastra di guida	347105
10	Zylinderschraube	Fillister head screw	Vis à tête cylindrique	Vite a testa cilindrica	081007
11	Schutzblech kompl.	Protection cover compl.	Couvercle de protection compl.	Coperchio di protezione compl.	347113 R
12	Steckwelle	Shaft	Arbre	Albero	347110 R
13	Zugfeder	Traction spring	Ressort de traction	Molla di trazione	061056
14	Spiralspannstift	Spiral pin	Goupille spiralée	Spina elastica	088087
15	Druckschieber	Pressure slide	Curseur	Cursore di pressione	347103 R
16	Sicherungsring	Locking ring	Circlip	Anello di sicurezza	059060
17	Schrägkugellager	Angular ball bearing	Roulement à rouleaux	Cuscinetto a sfere a pno. incl.	057159
—	Nutrollen-Satz 2–6" Pos. 18, 19, 20	Grooving rollers set 2–6" Pos. 18, 19, 20	Rouleaux à rainurer jeu 2–6" Pos. 18, 19, 20	Rulli di scanalatura serie 2–6" Pos. 18, 19, 20	347035
	Nutrollen-Satz 1–1 1/2"	Grooving rollers set 1–1 1/2"	Rouleaux à rainurer jeu 1–1 1/2"	Rulli di scanalatura serie 1–1 1/2"	347030
	Nutrollen-Satz 8–12"	Grooving rollers set 8–12"	Rouleaux à rainurer jeu 8–12"	Rulli di scanalatura serie 8–12"	347040
	Nutrollen-Satz Cu 54–159 mm	Grooving rollers set Cu 54–159 mm	Rouleaux à rainurer jeu Cu 54–159 mm	Rulli di scanalatura serie Cu 54–159 mm	347034
	Nutrollen-Satz 2–6" INOX	Grooving rollers set 2–6" INOX	Rouleaux à rainurer jeu 2–6" INOX	Rulli di scanalatura serie 2–6" INOX	347046
19	Gewindestift	Grub screw	Vis sans tête	Perno filettato	084036
21	Hauptwelle	Main shaft	Arbre	Albero	347102 R
22	Zylinderrollenlager	Cylindric roller bearing	Roulement à rouleaux cylindr.	Cuscinetto a rulli cilindrico	057158
23	Sicherungsring	Locking ring	Circlip	Anello di sicurezza	059017
24	Grundkörper	Body	Corps	Corpo	347101 R
25	Hochdruckschlauch	High pressure hose	Tuyau à haute pression	Tubo d'alta pressione	044106
26	Verschraubung	Screwing	Raccord	Raccordo	045150
27	Spiralspannstift	Spiral pin	Goupille spiralée	Spina elastica	088126
28	Einstellscheibe	Disc	Disque de réglage	Piastra di calibro	347109 R
29	Federdruckstück	Spring pressure piece	Element d'arrêt à bille	Elemento premente elastico	061053
30	Schmiernippel	Lubricating nipple	Graisser	Ingrassatore	064004
31	Sicherungsring	Locking ring	Circlip	Anello di sicurezza	059045
32	Kugellager	Ball bearing	Roulement à billes	Cuscinetto a sfere	057157
33	Nutmutter	Groove nut	Ecrou à rainure	Dado scanalato	085051
34	Trägerplatte REMS	Carrier plate REMS	Plaque d'appui REMS	Cartella REMS	347114 R
	Trägerplatte Ridgid 300	Carrier plate Ridgid 300	Plaque d'appui Ridgid 300	Cartella Ridgid 300	347130 R
	Trägerplatte Ridgid 535	Carrier plate Ridgid 535	Plaque d'appui Ridgid 535	Cartella Ridgid 535	347140 R
	Trägerplatte Super-Ego N 80 A	Carrier plate Super-Ego N 80 A	Plaque d'appui Super-Ego N 80 A	Cartella Super-Ego N 80 A	347150 R
	Trägerplatte Rex Delta 4	Carrier plate Rex Delta 4	Plaque d'appui Rex Delta 4	Cartella Rex Delta 4	347145 R
35	Sechskantmutter	Hexagon nut	Ecrou hexagonal	Dado esagonale	085004
36	Zylinderschraube	Fillister head screw	Vis à tête cylindrique	Vite a testa cilindrica	081029
38	Sicherungsscheibe	Locking washer	Rondelle de sécurité	Ranella di sicurezza	059079
39	Vorschubhebel	Feed lever	Levier	Leva d'avanzamento	347125
—	Hand-Hydraulikpumpe Pos. 38, 39, 40, 41	Hydraulic hand pump Pos. 38, 39, 40, 41	Pompe hydraulique manuelle Pos. 38, 39, 40, 41	Pompa idraulica manuale Pos. 38, 39, 40, 41	347121 R
—	Dichtungs-Reparatursatz für Hand-Hydraulikpumpe	Seal repair kit for hydraulic hand pump	Joint set de rep. pour pompe hydraulique manuelle	Guarnizione set di rip. per pompa idraulica manuale	347123
41	Querstift	Axle	Axe	Asse	347126
42	Zylinderschraube	Fillister head screw	Vis à tête cylindrique	Vite a testa cilindrica	081031
43	Scheibe	Washer	Rondelle	Ranella	086003
44	Winkelverschraubung	Angle screwing	Raccord angulaire	Raccordo ad angolo	045149
45	Verlängerung kompl. für Ridgid 535, Rex Delta 4	Extension compl. for Ridgid 535, Rex Delta 4	Rallonge compl. pour Ridgid 535, Rex Delta 4	Prolunga compl. per Ridgid 535, Rex Delta 4	347135 R